

Changing Trends in Banking Services: Technological Advancements

Karun Madan, Surya World Institute of Engg. & Technology, Rajpura, Punjab

ABSTRACT

Since the introduction of banking sector in our country and in other countries, traditional banking system has been serving the mankind in a good way. For the last decade, banking has taken a new form, banking at customer's own location. Mobile banking has come into view as a powerful provider of bunch of banking services. The worldwide adoption of mobile banking will depend on the secure, reliable and effortless user interfaces. In recent years, M-banking has emerged as the main division of e-commerce and m-commerce. Nowadays, Mobile banking services comprises of information inquiry, notifications as well as alerts, payment transfer etc. Mobile application handset is used for linking customer handset with the server of the bank for all above mentioned services.

This paper examines some significant standards and protocols, exercised in mobile banking and discusses mobile banking services.

INTRODUCTION

As mobile banking is a new system for customers to perform transactions, which is by far a convenient method for banking transactions and this practice is going to increase more rapidly in future also. Mobile banking has come forward as a capable new application of the next generation commerce - mobile commerce. A new communications technology is redefining the union of communications and computing[1]. Mostly banks are using secure payment gateway as well as security measures, which increases their cost and infrastructure for their bank[2]. But major day-to-day banking activities are not only payment transfer but inquiries, notifications and alerts as well.

GSM is the solitary network for transporting data in mobile banking. Approximately 80 percent of all mobile phones all around the world are branch of this network[3]. This has led many developers to investigate extra convenient methods for customers to perform mobile banking transactions. Mobile banking is a new system for customers to

International Journal of Computing and Corporate Research IJCCR India

Paper ID : ISSN2249054X-V111M12-072011

perform transactions, and is predicted to increase more rapidly in future also.

This paper is organized as follows: at first, there is working definition of mobile banking, then investigates the technical developments which escort the emergence of mobile banking, followed by a discussion of the procedures and protocols available for the performance of mobile banking applications[4]. At the end, review of future of mobile banking is presented.

MOBILE BANKING: INTRODUCTION AND BACKGROUND DEVELOPMENTS

Twenty years back, almost immediately after realization of the Internet as a way for banking services, banks as well as telecommunications companies started to work together towards the advancement of an online banking service based on mobile communication[5]. Work was done aimed at enhancing the screen and the keyboard of the mobile phone strive to convert it into a usable and portable “pocket “cash point” device[6]. Meanwhile, banks and other financial institutions had sensed the huge potential of the Internet and the escalating need for more Internet banking.

While online banking described above can be carried by a customer sitting in front of a

personal computer at home, the personal computer at home is not always the best platform at times, because personal computers or laptops are normally shared among the peers. Mobile phones, on the other side, are in actual, personal devices[7]. They are meant to be carried by their owner and not supposed to be used by another party[8]. This privacy feature and its portability made the mobile phone very well suited for financial banking services requiring high degree of confidentiality.

TRENDS IN MOBILE TELEPHONE SERVICES

In most of the countries, mobile telephones are dominated by GSM (Global System for Mobile Communication) which holds more than 70% to80% of the mobile telephony market. Digital mobile services offer voice communication as major part and secure data communication[9]. Mobile phones are operational with a SIM (Subscriber Identification Module card). The SIM card can accumulate user data.

access to the Internet at portable device platform.

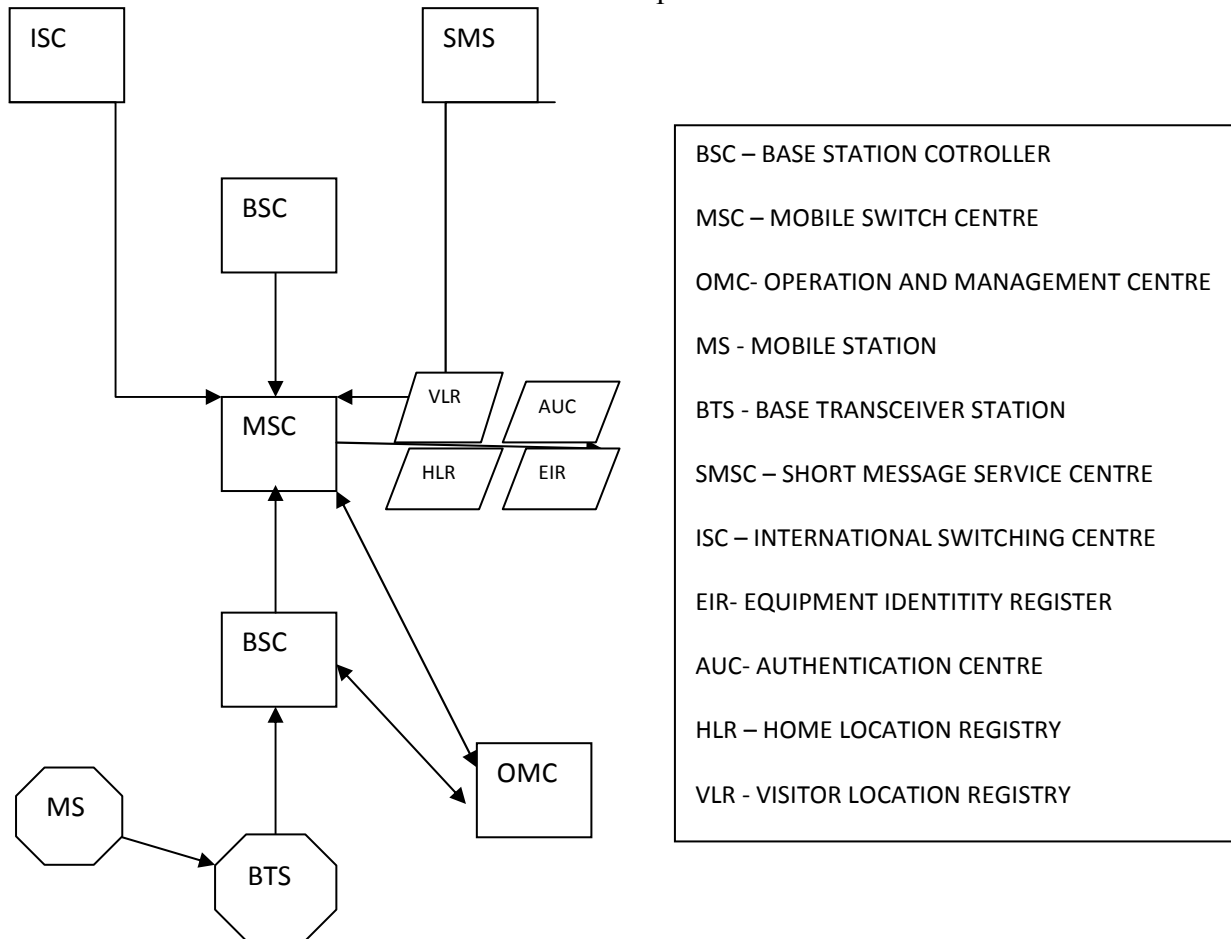

Figure 1. GSM Architecture

The steady growth of GSM users during last decade suggests that the number of mobile banking users will also grow. Current developments in mobile telephony include applications based on WAP (Wireless Application Protocol)[10], which allows full

LATEST COMMUNICATION TECHNOLOGIES

In the recent past, mobile communications standards evolution take in 2G (second generation) communication (like GSM), 2.5G technologies and youngest among them 3G (third generation) technologies[11]. The de facto standard in this kind of global communications is GSM. In contrast to analogue telecommunication,

cellular standards, which are précised only at the level of the air interface, GSM is totally specified and all the subsequent generations derive from these initial standard.

UMTS (Universal Mobile Telecommunications System) is a representative of the third generation technologies, which put forward packet-based transmission of text, voice, video, and multimedia with a everlasting connection to the Internet communication at a speed up to 2 Mbps[12]. A 3G mobile phone is actually a multi-purpose device which can be used as a phone or as a computer device.

Multiplexing techniques for UMTS are wide band-CDMA (WCDMA) as well as time division-code division multiple access (TD-CDMA). Japanese standard NTT DoCoMo is one of the well-known applications of 3G communication[13]. Work is going on towards continuous improvement of wireless networking technologies in various fields. While 3G has been penetrated in almost every region in this world, research on fourth-generation technologies is already going on.

ROLE OF WIRELESS APPLICATION PROTOCOL (WAP)

WAP is a client-server application paradigm for mobile devices and servers. It allows the use of mobile phones for Web browsing and banking etc. WAP paradigm for wireless communications takes into account the shortcomings of wireless data networks as compared to the wired networks and the downside of mobile handsets as compared to personal computers[14]. The development of the data compression and error correction techniques permit WAP enabled devices to offer high quality data transmissions over very slow and seldom reliable GSM network.

Fundamental mobile banking services include activities such as account balance

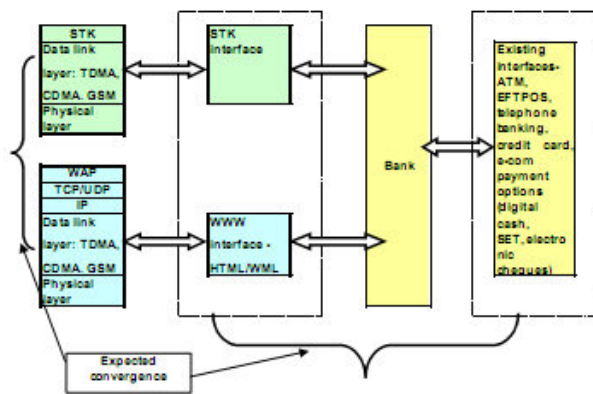

Figure 2 A Framework For Mobile Banking Services

International Journal of Computing and Corporate Research IJCCR India

Paper ID : ISSN2249054X-V111M12-072011

checking, credit limit checking and funds transfer from one account to another. Customers look forward to new types of services to be offered by the emerging technology, innovation in mobile banking faces many challenges. As basic services of banking remain same, but the ease and approach is different.

CONCLUSION & FUTURE WORK

Nowadays, Mobile banking services comprises of information inquiry, notifications as well as alerts, payment transfer etc. Mobile application handset is used for linking customer handset with the server of the bank for all above mentioned services. Most of the banks, nowadays have taken benefit of these protocols to secure transactions upto some extent Even though WAP an WIG protocols provide security for banking transactions upto some extent but still there are some loopholes that could prove susceptible for transactions on mobile banking. But as we have seen, these security protocols overlaid the GSM network for adding stronger authentication and confidentiality methods for secured communication, but these protocols are still susceptible for security threats. Any third party can acquire sensitive information from bank or from client. In order to cure this

problem, further work on authentication of mobile application is needed.

REFERENCES

- [1] Kelvin Chikomo, Ming Ki Chong, Alapan Arnab, Andrew Hutchison. Security of Mobile Banking
- [2] Birch, D ., “Mobile Financial Services: The Internet Isn't the Only Digital Channel to Consumers”, Journal of Internet Banking and Commerce, Vol .4, No.1 (1999): www.arraydev.com/commerce/JIBC/articles.htm.
- [3] Brewin, B., “ Study: Mobile Commerce Loses Luster”, ComputerWorld, May 11 (2001): 16-19.
- [4] Creed, A., “CBA Launches Australia's First Mobile Banking Service”, News Bytes News Network, Nov24 (1999): 9-11.
- [5] Drexelius, K. & Herzig, M., “Mobile Banking and Mobile Brokerage - Successful Applications of Mobile Business?”, International management & Consulting, Vol.16, No. 2 (2001): 20-23.
- [6] Engen J., “Banking on the Run”, Banking Strategies, Vol. 76, No. 4 (2000): 16-25.
- [7] Enos, L., “Commerce Slow to Connect in U.S.”. Wireless NewsFactor , Nov 17 (2000): <http://www.wirelessnewsfactor.com/perl/story/5368.html>
- [8] Matskin, M. & Tveit, A., “ Mobile Commerce Agents in WAP-based Services”, Journal of Database Management, Vol. 12, No. 3 (2001): 27-31.
- [9] Mitchell, J., “The Evolving Definition of E-Commerce”, Australian National Training

International Journal of Computing and Corporate Research IJCCR India

Paper ID : ISSN2249054X-V111M12-072011

Authority, Sept 13 (2001):
<http://www.jma.com.au/ecomdef.htm>

[10] Margrave, D. *GSM Security and Encryption*. Available from:
<http://www.hackcanada.com/blackcrawl/cell/gsm/gsmsecur/gsm-secur.html> (1999);
accessed 27 October 2006.

[11] SMS Spoofing: Everything you ever wanted to know about SMS spoofing.
<http://www.smsspoofing.com>, 2008.

[12] Burak Bayoglu: Performance evaluation of WTLS handshake protocol using RAS and elliptic

curve cryptosystems, 2004

[13] Wagner, D. *GSM Cloning*. Smartcard Developer Association and ISAAC security research group. Available from:
<http://www.isaac.cs.berkeley.edu/isaac/gsm.html> (1998); accessed 28 October 2006

[14] R. Chaudhri, G. Borriello, and W. Thies. FoneAstra: Making mobile phones smarter. In ACM Workshop on Networked Systems for Developing Regions. ACM, Oct. 2009